

SC 60 Sandmaster

Sandmaster SC 60

Key Features

- 2440mm x 914mm (8'x3') Reverse slope linear motion dewatering screen
- 2 x 1.9kW vibrating motors
- 24 Polyurethane panels - 305mm x 305mm (1' x 1')
- Adjustable amplitude
- 460mm (18") hydrocyclone
- 150/125 Centrifugal Slurry Pump complete with 15kW motor
- Sump tank 4100 ltrs (900 UK Gal)
- Sump tank 2725 lpm/min (600 UK Gpm / 720 US gpm) - water requirement
- Output capacity up to 60 tph (dependent on application and type of material)

Dimensions

Transport:	Length	7 500mm	(24' 7")
	Width	2600mm	(8' 6")
	Height	3300mm	(10' 10")

Working:	Length	5500mm	(18')
	Width	2600mm	(8' 6")
	Height	5300mm	(17' 5")

Weight

Empty:	6000kgs	(13,225lbs)
Working- Maximum:	26000kgs	(57,320lbs)

Dewatering screen

- VD9 Reverse slope linear motion dewatering screen
- 2x 1.9kW Vibrating motors
- Direct force screen 2440mm x 914mm (8' x 3')
- 24 Polyurethane panels- 305mm x 305mm (1' x 1')
- Adjustable amplitude

Cyclone

- Type 518 460mm (18") Hydrocyclone

Pump

- 150/125 Linapump complete with 15kW motor

Capacities

Sump tank:	4100 Litres	(900 UK Gal)
	2725 lpm	(600 UK gpm/ 720 US gpm) – Water requirement

Output Capacity: Up to 60tph (Dependant on application and type of material)

Sandmaster SC 60

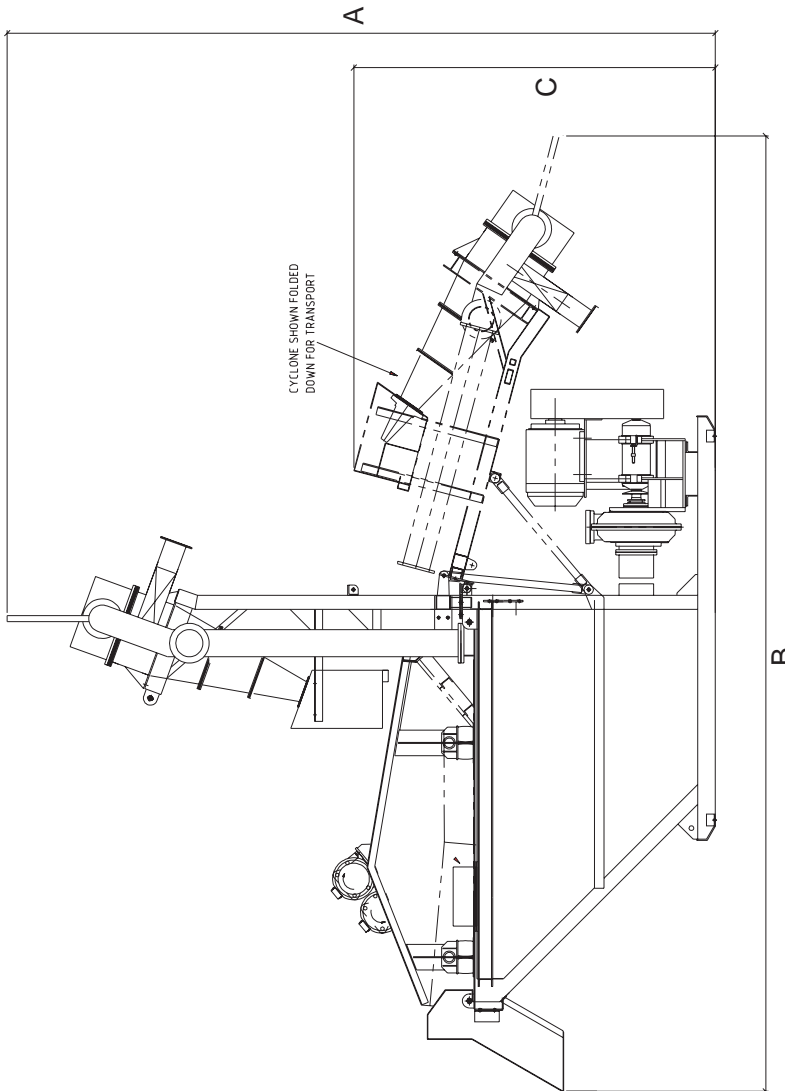
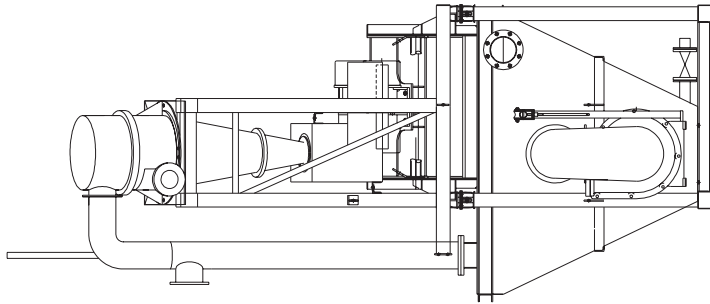

Dimensions- Working mode

Length: 5500mm (18')
 Width: 2600mm (8' 6")
 Height (A): 5300mm (17' 5")
 Weight: 26000Kgs (57,320 lbs) *
 *Max working weight

Dimensions- Transport mode

Length (B) : 7500mm (24' 7")
 Width: 2600mm (8' 6")
 Height (C): 3300mm (10' 10")
 Weight: 6000Kgs (13,225 lbs) **
 **Empty weight

Sandmaster SC 60